









Item #	Illustration	Part Number	Qty.
1		82-05010-100 "U" Bracket for LCD Suspension System	1
2		15-00090-100 Flat Panel Monitor Mounting Plate 100 mm	1
3		82-05010-040 Carriage for Truck	1
4	 <i>Includes hardware</i>	15-00048-L17 Flat Panel Monitor Mount Tilt/Swivel & Rotate	1
5		83-52000-175 Nat Deirin Step Rollers	4
6		82-28001-060 3/8-16 x 1" Socket Head Cap Screw	1
7		82-28002-035 3/8-16 x ESNA Lock Nut	1
8		83-28004-065 3/8 Nylon 6/6 Washer .39 ID, .75 OD, .062 Thick	2
9		83-28004-025 3/8" x 1" OD Washer	1

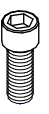