

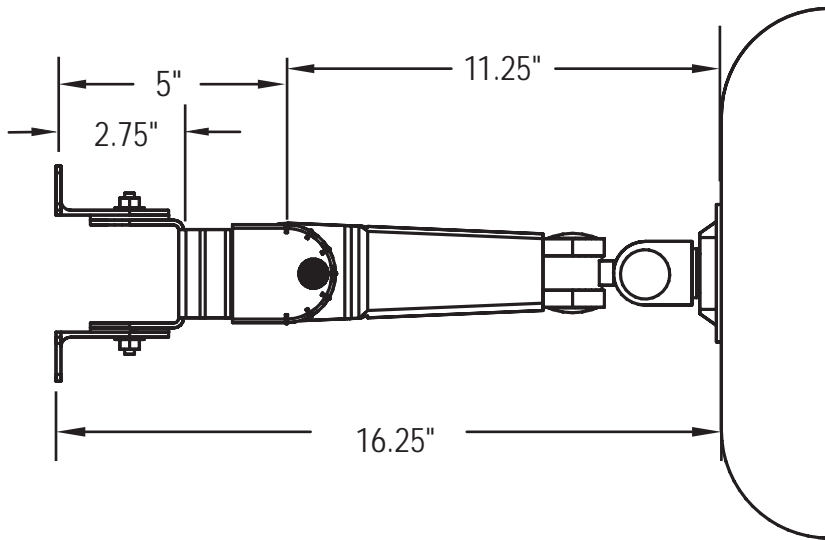

56-01 55TH AVENUE  
MASPETH, NY 11378  
888.222.7270  
www.hergo.com

# LCD Monitor Wall Mount Secured Angle Arm (PN 15-00036-L12)

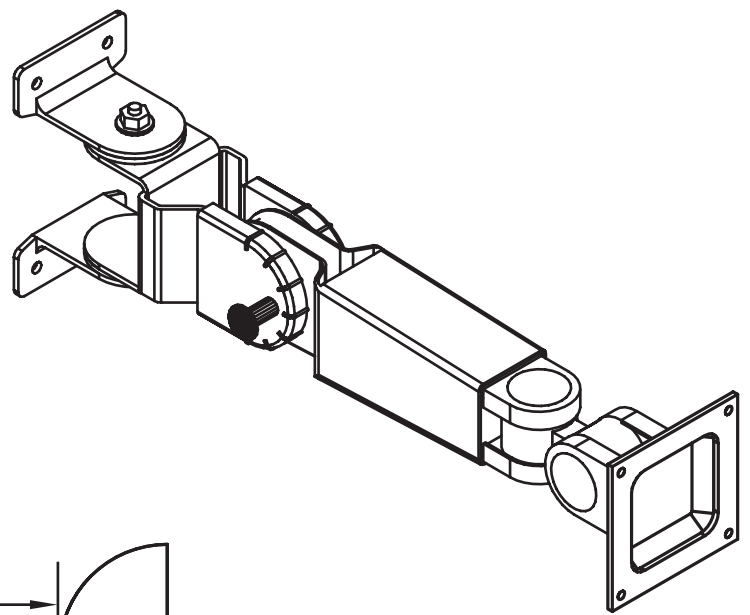

Wall Mount Plate

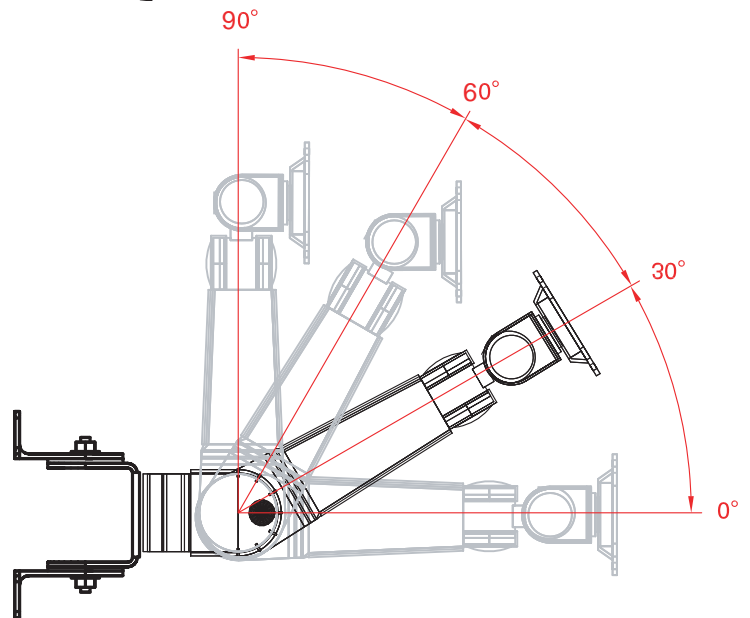
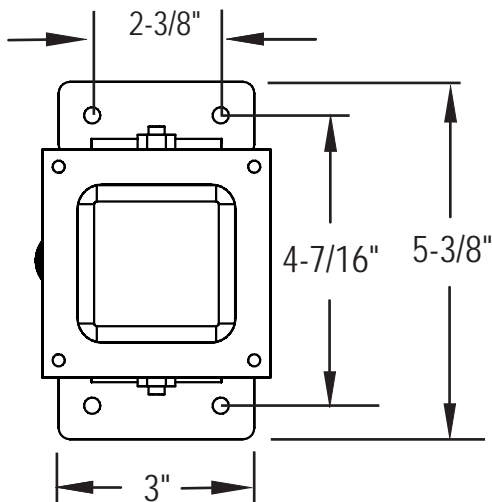

UNLESS OTHERWISE SPECIFIED  
DIMENSIONS ARE IN INCHES  
TOLERANCES  
2 PL DECIMALS ± .01  
3 PL DECIMALS ± .005

NEXT ASS'Y:

FLAT PANEL ARMS 15-00036-L12

DATE: 6/11/2002

hergo