

# INSTALLATION AND ASSEMBLY DETAILS

## FOR HERGO TECHNICAL FURNITURE



Modular Ergonomic Technical Furniture  
Enclosures and Cabinets for Computers,  
Data & Communications Equipment



TECHNICAL WORKSPACE SOLUTIONS

WWW.HERGO.COM



888.222.7270

Hergo Ergonomic Support Systems, Inc. 56-01 55th Avenue, Maspeth, New York 11378

Tel: 888-222-7270 | Fax: 888-410-0671

## LEG ASSEMBLY

- A. Insert bolts into each hole to attach the Leg Assembly to the Frame (Fig. 1).
- B. Tighten bolts using a 7/16" socket. Repeat steps A & B for additional Leg Assemblies.

Frame uprights are 1" W x 2" D, Legs are 2" W.  
This allows two possible ways to position the Legs in relation to the Frame. The side of the Leg can be aligned flush with the side of the Frame, (Fig. 2) or the side can extend 1" outside the Frame (Fig. 3).

The second position will enable the user to add a Side Panel, (Fig. 4) Upright Support Channel, (Fig. 5) or another Frame.

### HARDWARE USED IN THIS STEP

2-3/4" x 1/4" Hex Bolt (use 7/16" socket)

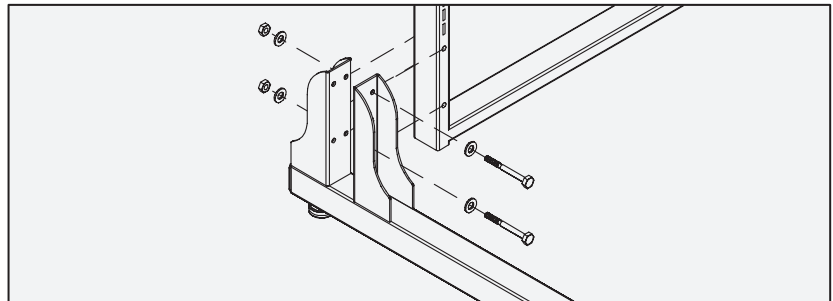

Leg Assembly Detail

Fig. 1

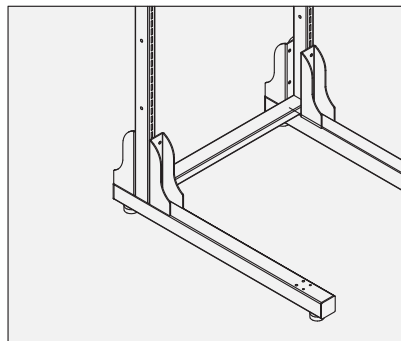

Leg Positioned  
Flush with Frame

Fig. 2

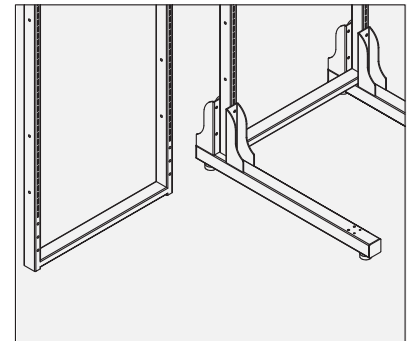

Leg Positioned  
Outside Frame

Fig. 3

## FRAME ASSEMBLY

- A. Hold (2) Frames adjacent to one another. Make sure the (2) holes for the Leg Assembly are at the bottom.
- B. Insert (2) bolts to attach the Frames at two positions (Fig. 4).

### HARDWARE USED IN THIS STEP

Two Frames - no Cable Raceways 2-1/2" x 1/4"  
Two Frames - one Cable Raceway 2-1/2" x 1/4"  
Two Frames - two Cable Raceways 2-3/4" x 1/4"  
One Frame - one Cable Raceway 1-1/2" x 1/4"

Hex Bolt (use 7/16" socket)



## UPRIGHT SUPPORT CHANNEL ASSEMBLY

Insert bolts into the holes at the top and bottom of the Upright Support Channel (Fig. 5).

### HARDWARE USED IN THIS STEP

2-1/2" x 1/4" Hex Bolt (use 7/16" socket)

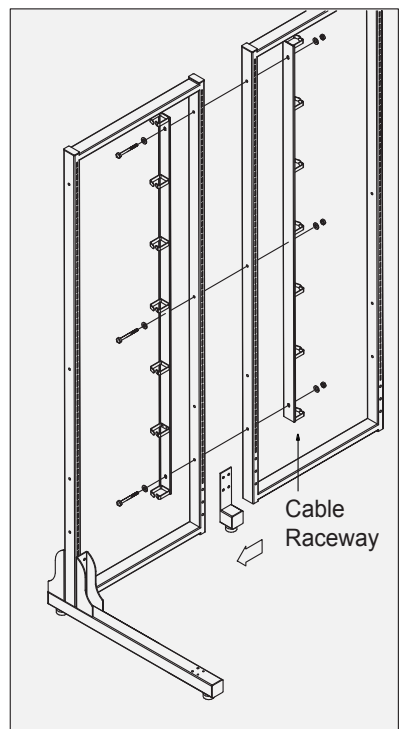

Leg Positioned  
Outside Frame

Fig. 4

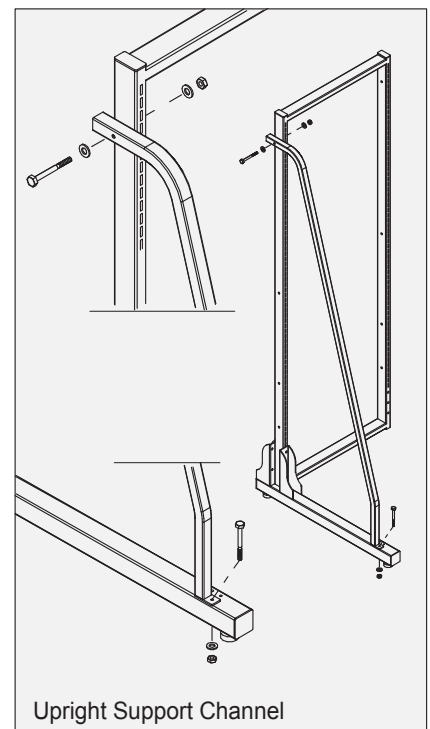

Upright Support Channel

Leg Positioned  
Outside Frame

Fig. 5

## CENTER SUPPORT LEG

It is necessary to attach a Center Support Leg whenever (2) Frames are joined without a Standard, Mini or Double-Sided Leg.

- A. Place the Center Support Leg in back of the Frames to be joined (Fig. 6A).
- B. Align the holes on the Center Support Leg with the holes on the Frame (Fig. 6B).
- C. Insert the bolts into each hole, attaching the Center Support Leg to the Frames (Fig. 6A).
- D. Tighten bolts using a 7/16" socket.

### HARDWARE USED IN THIS STEP

2-3/4" x 1/4" Hex Bolt (use 7/16" socket)

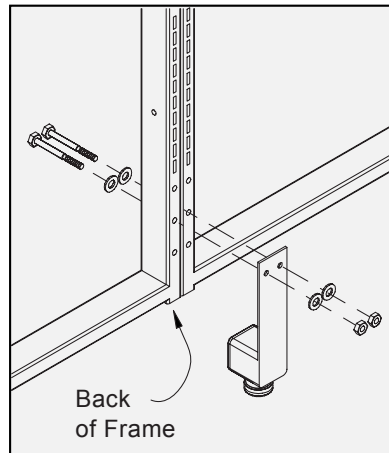

Fig. 6A

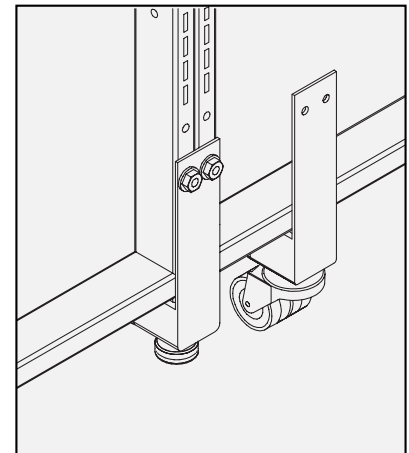

Fig. 6B

(Fig. 6B) Repeat steps A-D for Center Support Leg with Caster

## GLIDERS AND CASTERS

- A. Adjust height of Gliders (or Casters) on both sides by turning them counter clockwise until structure is completely stable (Fig. 7A & 7B).
- B. Screw Glider/Caster into Leg before attaching to Frame.

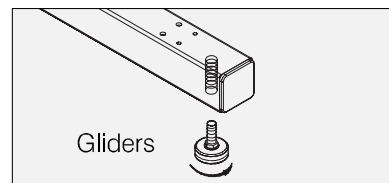

Fig. 7A

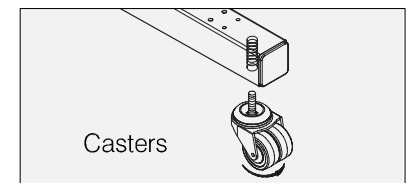

Fig. 7B

## SHELVES

- A. Mounting Shelves and Book Shelves are available with upward or downward facing brackets (Fig. 8B).
- B. Attach left and right brackets to Shelf using cap nuts (Fig. 8A). Cap nuts are included with Shelf. Note the Center Support Bracket is only included with 48" and 60" Wide Shelf Assemblies.
- C. Mark slots on both sides of Frame at the same level at which shelf is to be mounted (Fig. 8B).
- D. Insert Shelf with bracket "teeth" facing downward into vertical slotting on Frame (Fig. 8C).
- E. Push Shelf down firmly for secure placement and correct positioning.

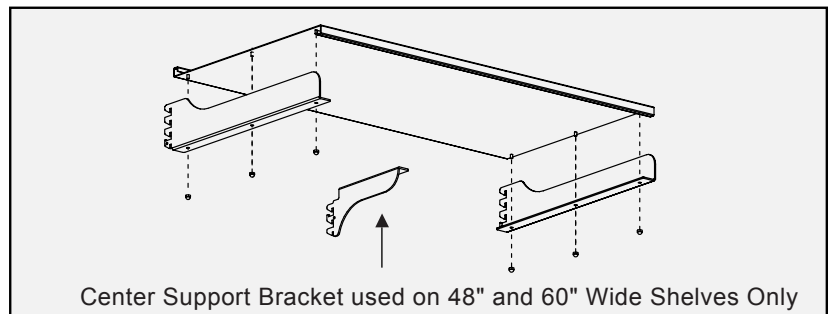

Fig. 8A

Follow the same procedure for Tilted Shelves (Fig. 8D)

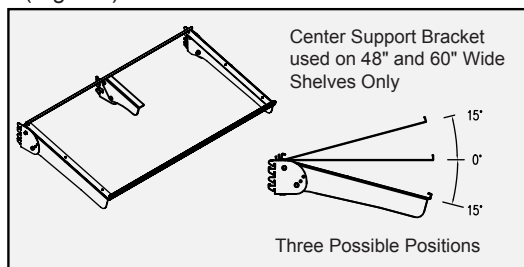

Fig. 8D

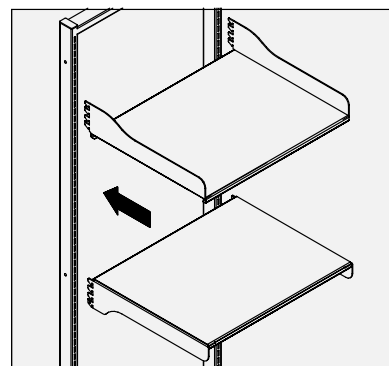

Fig. 8B

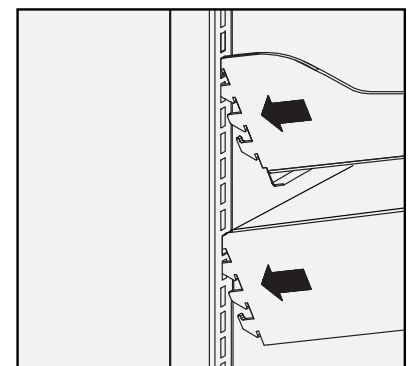

Fig. 8C

## ATTACHING THE LCD SUSPENSION ARM & ASSEMBLING THE MONITOR TRACK SHELF

A Monitor Track Shelf is required whenever an LCD Suspension Arm is used. The Monitor Track Shelf Assembly consists of a left and right bracket, a track, a shelf plate and mounting screws (Fig. 9).

- A. Attach the track to the left bracket using (2) screws (Fig. 9). Note there are (3) possible locations for attaching the track to the brackets, front, center, or back.
- B. Slide the LCD Suspension Arm onto the track.
- C. Position the shelf plate over the track and left bracket.
- D. Complete the assembly by attaching the right bracket using (2) screws (Fig. 9).

### HARDWARE USED IN THIS STEP

5/16-24" x 5/8" Button Head Screw

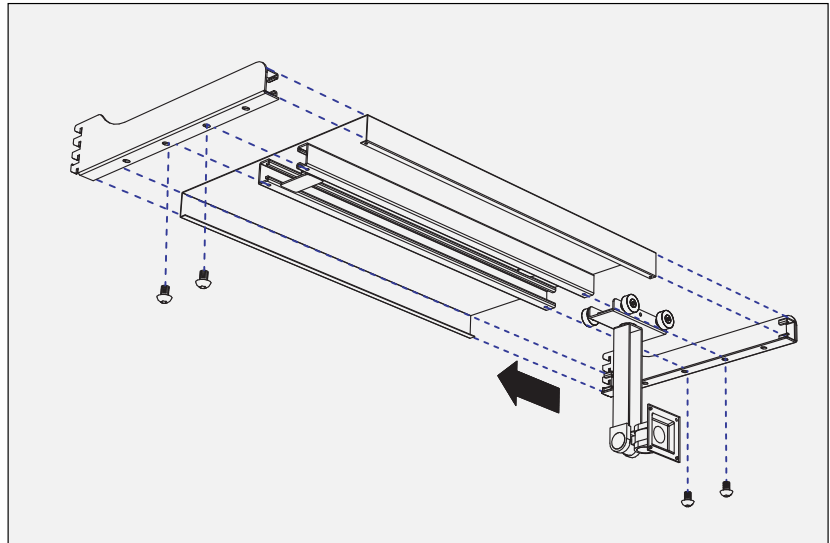

Fig. 9

## FLOOR SHELF STAND-ALONE & PULL-OUT

- A. Stand Alone Floor Shelf is pre-assembled with (4) Gliders (Fig. 10A). An Upgrade Kit is available to convert a Stand-Alone Floor Shelf into a Pull-Out. (Fig. 10B).
- B. Pull-Out Floor Shelf Upgrade Kit includes the following: (2) Lockable Casters, (2) Non-Lockable Casters, Floor Shelf Handle, and hardware to attach the handle.
- C. To assemble the Pull-Out Floor Shelf, unscrew the Gliders and replace them with the Casters-lockable in front, and non-lockable in back. Then, attach the handle using hardware provided.

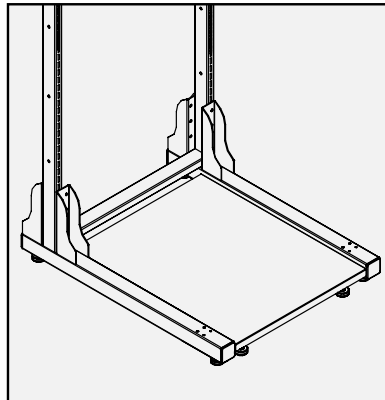

Fig. 10A

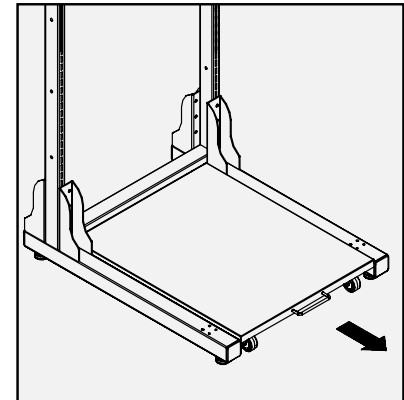

Fig. 10B

## FLOOR SHELF-LEG MOUNTED

- A. Attach Leg Mounted Floor Shelf to Leg using screw # 1, nut and washers (Fig. 11-Detail a). Note when adding a Telescopic Support Upright, use screw # 2, nut and washers (Fig. 11-Detail b).

### HARDWARE USED IN THIS STEP

- #1 Hex Head Bolt 3-1/2" x 1/4" (use 7/16" socket)
- #2 Hex Head Bolt 3-3/4" x 1/4" (use 7/16" socket)

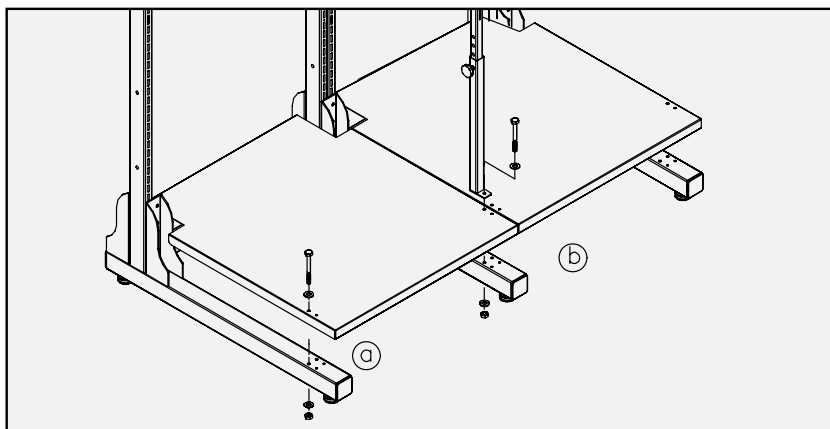

Fig. 11

## DESKTOP ASSEMBLY

- A. Insert Desktop Support Brackets firmly into vertical slotting with "teeth" facing downward (Fig. 12A).
- B. Line up Desktop Inserts with bracket holes and firmly attach the Desktop surface to the brackets using a Phillips Head Screw Driver (Fig. 12B).

### HARDWARE USED IN THIS STEP

1/4-20 x 1" Phillips Pan Head Screws

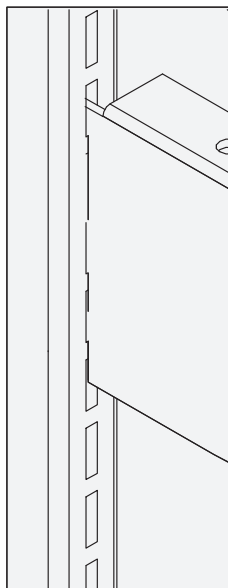

Fig. 12A

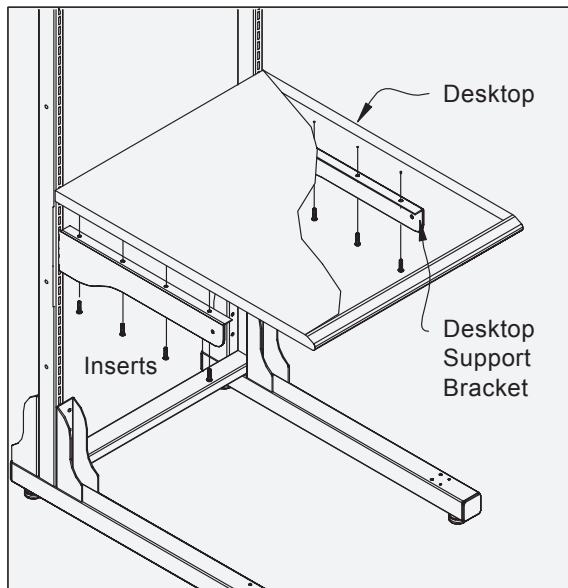

Fig. 12B

## ISLAND & PERSONAL WORKSTATION DESKTOP ASSEMBLY

Attach the Island or Personal Workstation Desktops as follows: (Note the Personal Workstation Desktops are available with a Right or Left Return. Left Return shown (Fig. 14A).

- A. Turn Desktop upside down and mount Round Leg Assembly at approximately 15" from the front edge of the Desktop to the edge of the flange plate, using (4) # 10 x 1" Phillips Pan Head Wood Screws and a Phillips Head Screw Driver (Fig. 13).
- B. Position the Desktop Brackets at desired location (Fig. 14A). (See Fig. 14B for Island Desktop). Note that the Island requires a Right and Left Desktop Bracket (Fig. 14B), while the Personal Workstation requires a Left, Right and Center Bracket (Fig. 14A).
- C. Turn Desktop Right side up and place on top of Desktop Brackets (Fig. 14A and 14B).
- D. Firmly attach the Desktop to the Desktop Brackets using # 10 x 1" Phillips Pan Head Wood Screw.

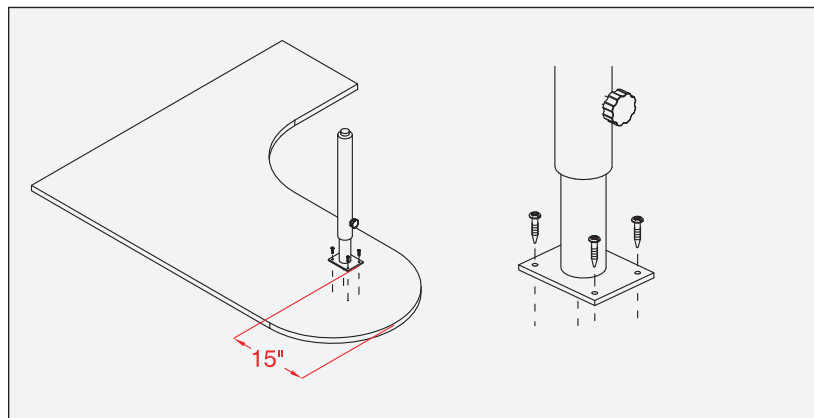

Fig. 13

### HARDWARE USED IN THIS STEP

# 10 x 1" Phillips Pan Head Wood Screw



Fig. 14A



Fig. 14B

## UNDER-DESK KEYBOARD TRAY

- Position Keyboard Tray Channel under Desktop at desired location.
- Mount Channel under Desktop using (8) Phillips Head Screws (Fig.15).
- Mount Black Plastic Stop to end of Channel.
- Slide Keyboard Tray Assembly into Channel.
- To prevent Keyboard Tray from sliding out of track, install Grommet after placing Tray onto the track.

**(Assembly Hardware Included)**

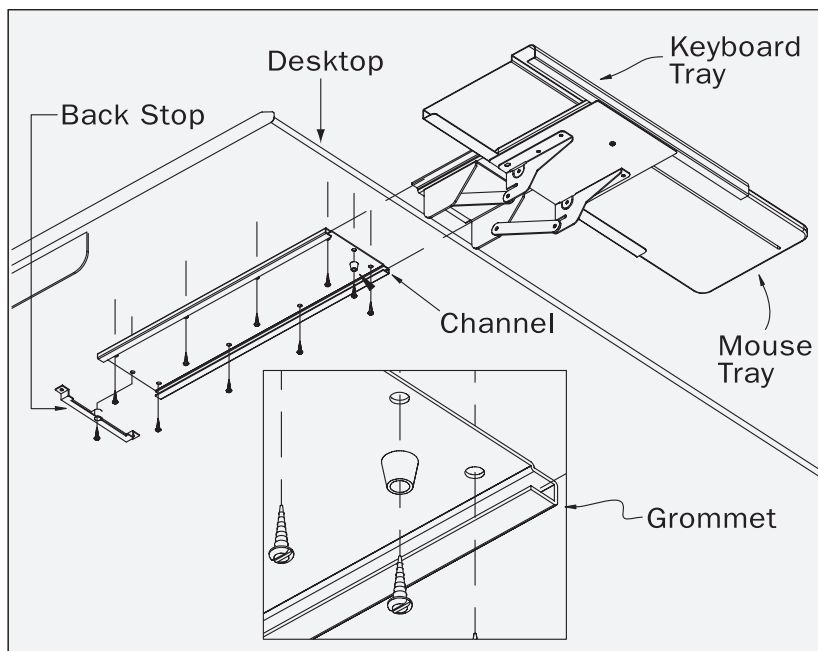

Fig. 15

## JOINING CORNER FRAMES

- Position (2) Corner Frames at a 90-degree angle. Connect the Frames using the Corner Support Kit, which includes (1) "L" Bracket, (1) Corner Support Leg and all necessary hardware to join Frames (Fig.16).
- Align holes on "L" Bracket with holes at top of Frame and tighten with bolt, (1-3/4" x 1/4") washers and hex nut.
- Align holes on Corner Support Leg with holes at bottom of Frames and tighten with bolts, (2-3/4" x 1/4") washers and hex nut.

### HARDWARE USED IN THIS STEP

- 1-3/4" x 1/4" Hex Head Bolt (use 7/16" socket)
- 2-3/4" x 1/4" Hex Head Bolt (use 7/16" socket)

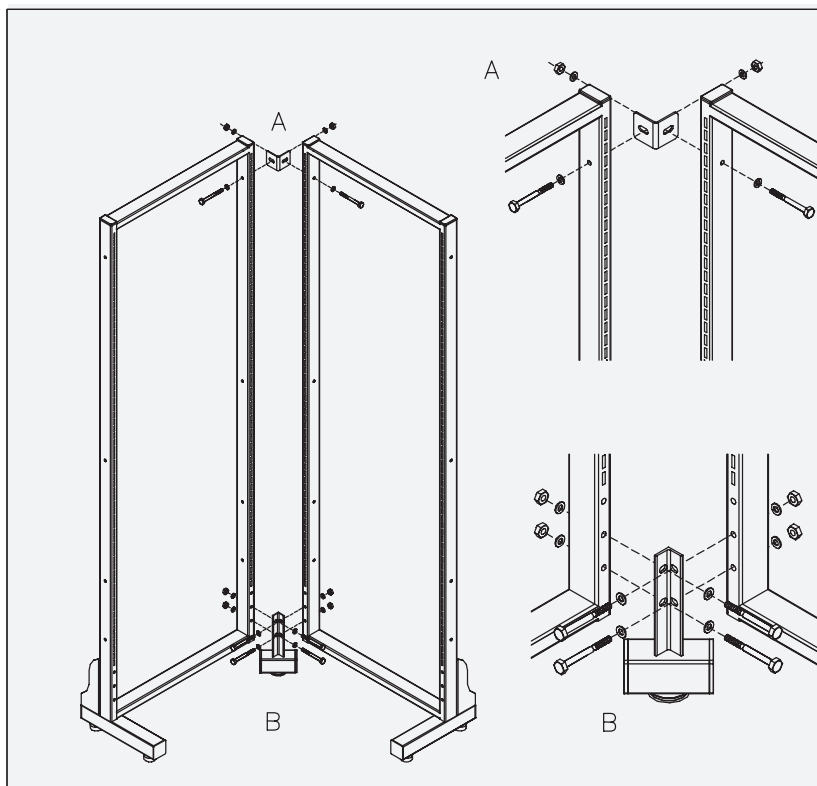

Fig. 16

## ADDING THE 42" CORNER DESKTOP

### STEP 1

- A. Place the Desktops on the floor with the bottoms facing up.
- B. Line up the adjacent Desktops evenly with the Corner Desktop (Fig. 17). Proceed to Step 2.

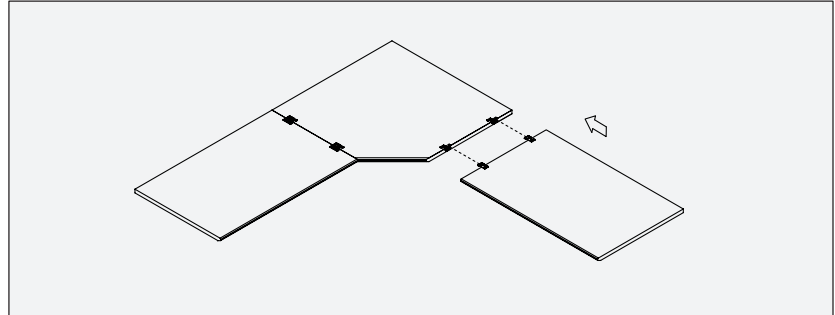

Fig. 17

### STEP 2

- A. Assemble the two halves of the Joint Leveler Support and attach the assembly to the corner and adjacent Desktop (Fig. 18A). Note the Joint Leveler is required in the front and the back of the Corner Desktop (Fig. 17), approximately 3-1/2" from the front edge (Fig. 18A).
- B. Remove the center screw from the Joint Leveler Support to separate the Desktops (Fig. 18B). Proceed to Step 3.

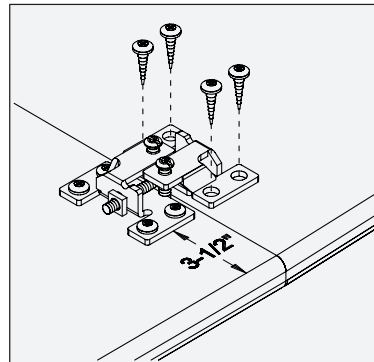

Fig. 18A

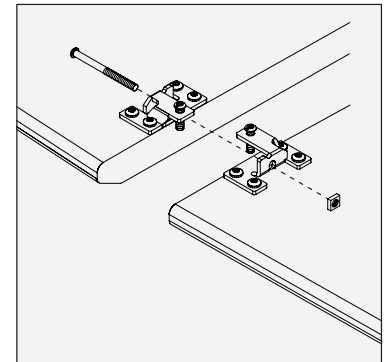

Fig. 18B

### HARDWARE USED IN THIS STEP

# 10 x 1" Phillips Pan Head Wood Screw



### STEP 3

- A. Mark the corresponding slots on the Frames for the placement of the Desktop Brackets (recommended height is 30" from the floor to the top of Desktop). Insert all Desktop Brackets (Fig. 19) into marked slots.
- B. Place the Desktop on top of the Brackets (laminated surface facing up). Secure the Desktop to the Brackets with screws (Fig. 19).

### HARDWARE USED IN THIS STEP

# 10 x 1" Phillips Pan Head Wood Screw

1/4-20 x 1" Phillips Pan Head Screw



Note: The Brackets labeled Inserts require the 1/4-20 x 1" screw. Use the # 10 wood screw on the remaining Brackets.

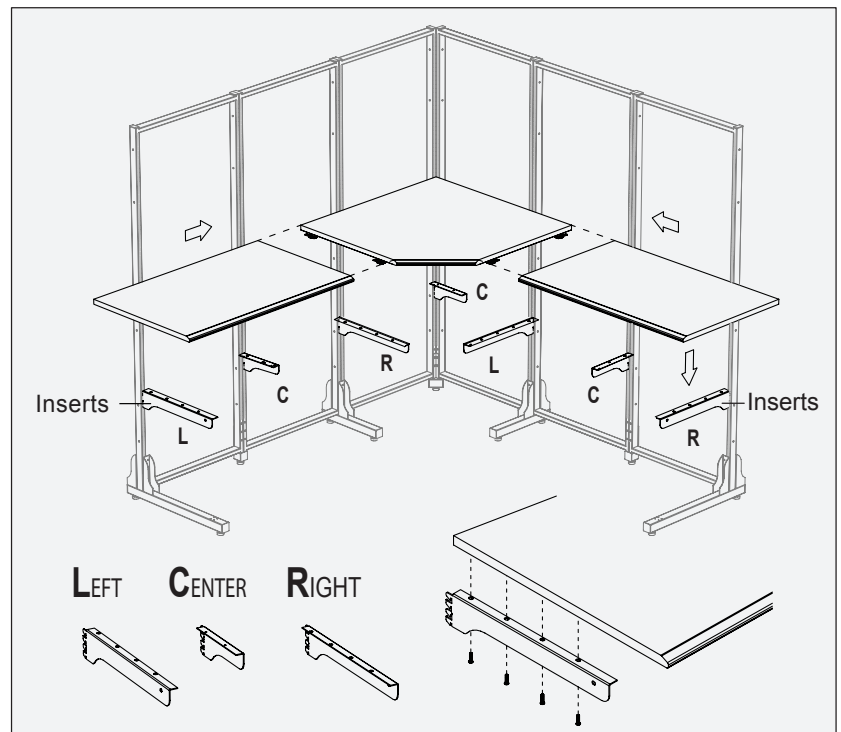

Fig. 19



## SIDE PANELS

To install a Side Panel, the Frame Legs must be positioned outside the Frame.

(See Page 2 Leg Assembly instructions).

- A. Place the Panel on top of the Leg using the cut-out at the base of the Panel as a guide. For 30"D Panels, use the Spring Roll Pin provided to attach the Panel to the front end of the Leg (Fig. 20A).
- B. Secure Panel to Frame at top, middle and bottom using the Panel Fasteners (Fig. 20B).

### HARDWARE USED IN THIS STEP

- Panel Fastener 
- Spring Roll Pin 

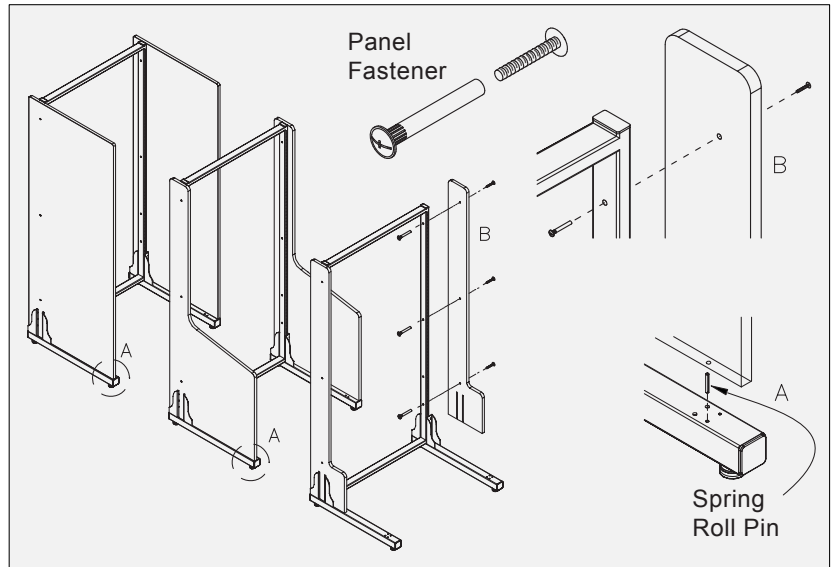

Fig. 20

## BACK PANELS

- A. Install (1) left and (1) right Back Panel Bracket into the pre-drilled / marked holes provided at the top of the Panel using #8 x 5/8" wood screws (Fig. 21). Do not tighten screws completely.
- B. Hang Panel on the back of the Frame. Make sure the top of the Panel is level with the top of the Frame.
- C. Insert (1) left and (1) right Back Panel Bracket onto the Frame near the bottom of the Panel and screw in tight (Fig. 22-Detail A).

### HARDWARE USED IN THIS STEP

- # 8 x 5/8" Phillips Pan Head Wood Screw

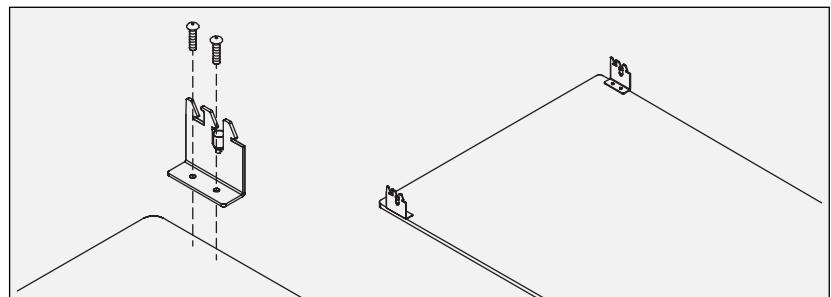

Fig. 21

Thank you for being a valued customer of Hergo. For further assistance, please contact your dedicated Hergo Account Manager.

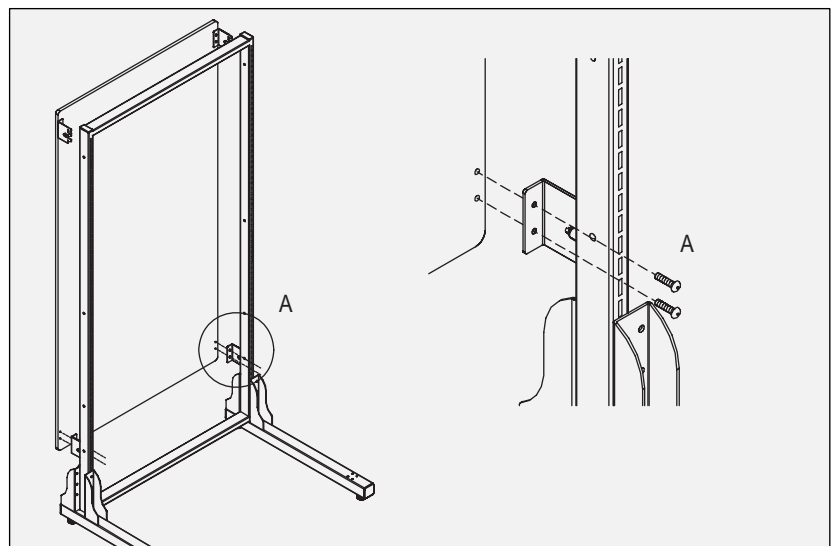

Fig. 22