





Hardware List

Illustration	Part Number & Description	Qty.
	83-28003-008 1/4-20 x 3-1/2" Hex Head Bolt	1
	83-28004-005 1/4" Washer	2
	83-28002-040 1/4-20 Nylon Insert Stop Nut	1

Note: Supplied with (1) Glider or (1) Caster

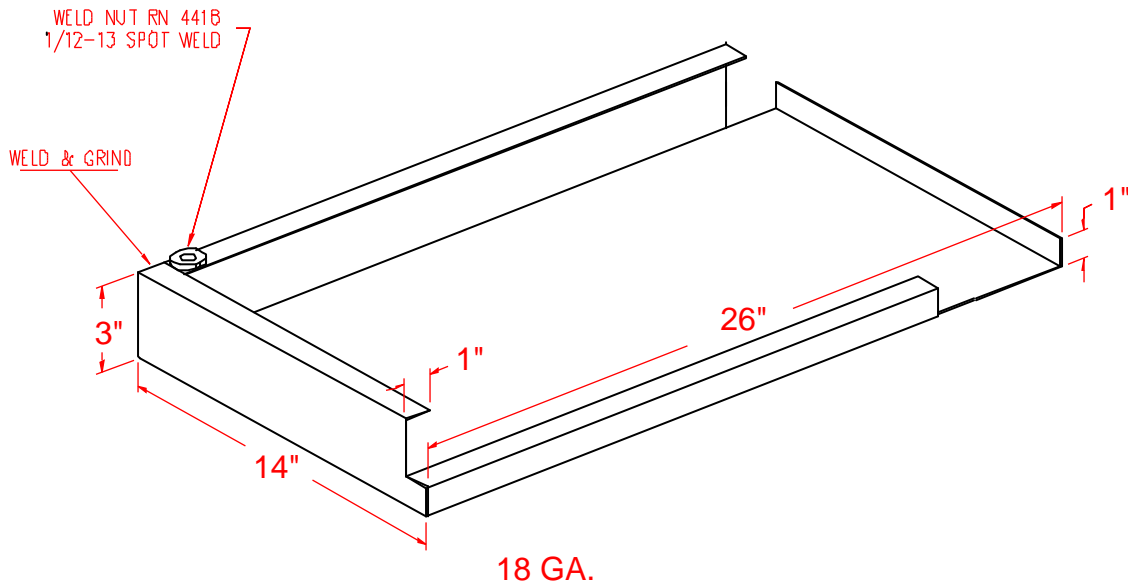

UNLESS OTHERWISE SPECIFIED DIMENSIONS ARE IN INCHES TOLERANCES 2 PL DECIMALS ± .01 3 PL DECIMALS ± .005	NEXT ASS'Y:	
	DATE:	