

Assembly View

Note:

Torque Wrench Supplied.
 Turn clockwise to increase tension for heavy weight monitors.
 Turn counter clockwise to reduce tension for light weight monitors.

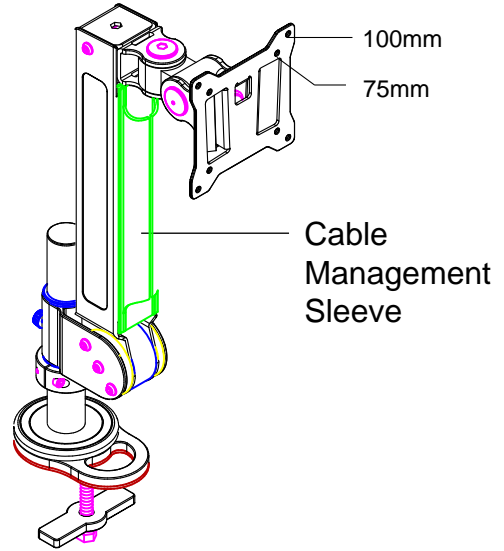
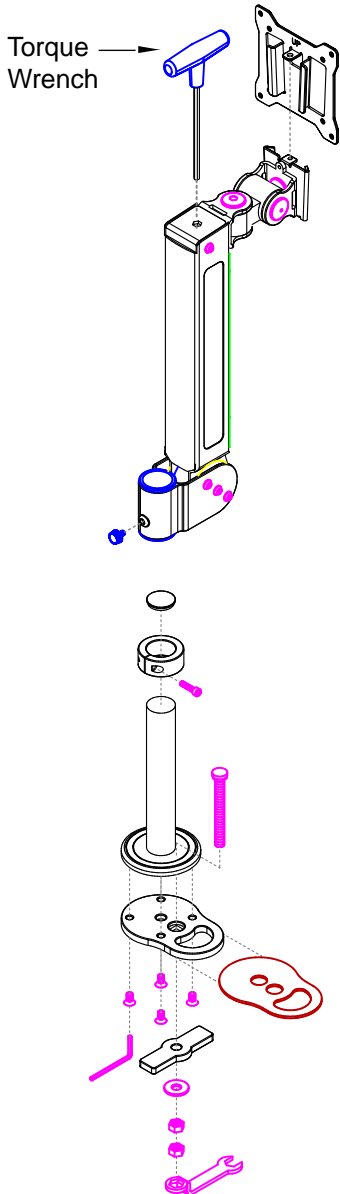

PN 15-00034-AL0
 Main Body Arm

PN 15-00034-AL2
 Grommet Mount

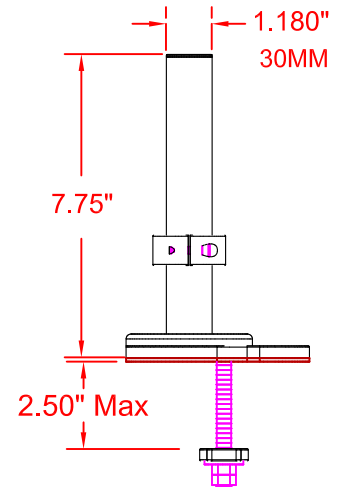
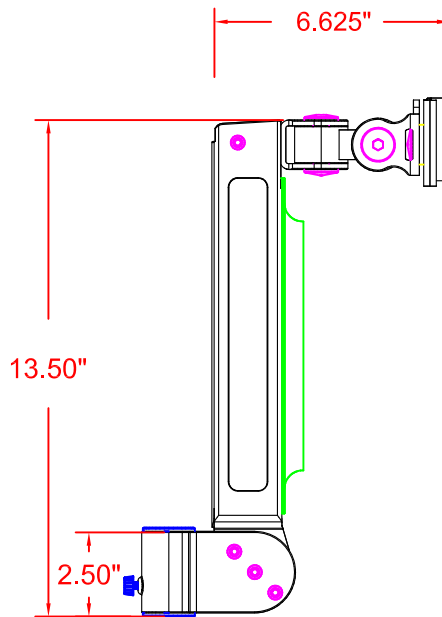

UNLESS OTHERWISE SPECIFIED
 DIMENSIONS ARE IN INCHES
 TOLERANCES
 2 PL DECIMALS ± .01
 3 PL DECIMALS ± .005

NEXT ASS'Y:

DATE: 12/06/12